

Specification of MEMS Microphone (RoHS Compliance & Halogen Free)

Customer Name :
Customer Model :
Goermicro Model : SD18OB371-167

Goermicro	CUSTOMER APPROVAL
<p>DESIGN <u>Chong Qin</u> 2023.08.09</p>	
<p>CHKD <u>Pauline Zhao</u> 2023.08.09</p>	
<p>STANDARD <u>Angela Kong</u> 2023.08.09</p>	
<p>APVD <u>Roy Wang</u> 2023.08.09</p>	

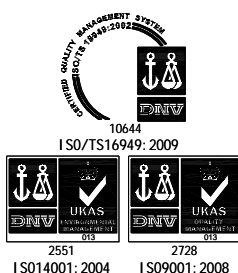

Tel : + 86 536 3051234
E- Mail : goermicro@goermicro.com
Website: <http://www.goermicro.com>
Address: No.268 Dongfang Road, High-Tech Industry
Development District, Weifang, Shandong, P.R.C.

Contents

1	Introduction	4
2	Test Condition	4
3	Acoustic and Electrical Characteristics	4
3.1	Standard Mode	4
3.2	Low Power Mode	4
3.3	Frequency Response Curve and Limits	5
3.4	Microphone Interface Specifications	6
3.5	Genal Microphone Specifications	7
4	Measurement Circuit	8
5	Test Setup Drawing	8
6	Mechanical Characteristics	9
6.1	Appearance Drawing	9
6.2	Weight	9
7	Reliability Test	10
7.1	Vibration Test	10
7.2	Drop Test	10
7.3	Temperature Test	10
7.4	Humidity Test	10
7.5	Mechanical Shock Test	10
7.6	Thermal Shock Test	10
7.7	Reflow Test	10
7.8	Electrostatic Discharge Test	10
8	Package	11
8.1	Tape Specification	11
8.2	Reel Dimension	12
8.3	The Content of Box	12
8.4	Packing Explain	13
9	Storage and Transportation	13
10	Land Pattern Recommendation	14
10.1	Recommended Land Pattern	14
10.2	Recommended Solder Stencil Pattern	14
11	Soldering Recommendation	15
11.1	Soldering Machine Condition	15
11.2	The Drawing and Dimension of Nozzle	15
11.3	Reflow Profile	16
12	Cautions	17
12.1	Board Wash Restrictions	17
12.2	Ultrasonic Restrictions	17
12.3	Acoustic Port Protection	17
13	Output Inspection Standard	17

1 Introduction:

MEMS MIC which is able to endure reflow temperature up to 260°C for 50 seconds can be used in SMT process. It is widely used in telecommunication and electronics device such as mobile phone, laptop computers, and other portable electronic devices etc.

2 Test Condition ($V_{DD}=1.8V$, $f_{CLK}=3.072MHz/2.4MHz/768kHz$, $L=50\text{ cm}$)

StandardConditions (As IEC 60268-4)	Temperature	Humidity	Air pressure
Environment Conditions	+15°C ~ +35°C	25%RH ~ 75%RH	86kPa ~ 106kPa
Basic Test Conditions	+20°C ± 2°C	60%RH ~ 70%RH	86kPa ~ 106kPa

3 Acoustic and Electrical Characteristics

3.1 Standard Mode

(Test Condition: $V_{DD}=1.8V$, $f_{CLK}=3.072MHz$, Decimation=64X)

Item	Symbol	Test Conditions	Min	Typ	Max	Unit
Sensitivity	S	94dB SPL @ 1kHz	-38	-37	-36	dBFS (Note 1)
Current Consumption (Note 2)	I	$f_{CLK}=3.072MHz$	-	440	600	µA
S/N Ratio	SNR	94dB SPL @ 1kHz A-Weighting	-	68.5	-	dB
Distortion	THD	THD < 1% @ 1kHz	-	126	-	dB SPL
Acoustic Overload Point	AOP	10% THD @ 1kHz, S=Typ	-	128	-	dB SPL
Power Supply Rejection	PSR	100mVpp Squarewave @ 217Hz A-weighting	-	-103	-	dBFS
Low Frequency Roll-off	LFRO	-3dB corner reference to 1kHz sensitivity	-	40	-	Hz
High Frequency Flatness		+3dB reference to 1kHz sensitivity	-	13	-	KHz

(Test Condition: $V_{DD}=1.8V$, $f_{CLK}=2.4MHz$, Decimation=50X)

Item	Symbol	Test Conditions	Min	Typ	Max	Unit
Sensitivity	S	94dB SPL @ 1kHz	-38	-37	-36	dBFS (Note 1)
Current Consumption (Note 2)	I	$f_{CLK}=2.4MHz$	-	400	550	µA
S/N Ratio	SNR	94dB SPL @ 1kHz A-Weighting	-	68	-	dB
Distortion	THD	THD < 1% @ 1kHz	-	126	-	dB SPL
Acoustic Overload Point	AOP	10% THD @ 1kHz, S=Typ	-	128	-	dB SPL
Power Supply Rejection	PSR	100mVpp Squarewave @ 217Hz A-weighting	-	-103	-	dBFS

3.2 Low Power Mode

(Test Condition: $V_{DD}=1.8V$, $f_{CLK}=768kHz$, Decimation=48X)

Item	Symbol	Test Conditions	Min	Typ	Max	Unit
Sensitivity	S	94dB SPL @ 1kHz	-38	-37	-36	dBFS (Note 1)
Current Consumption (Note 2)	I	$f_{CLK}=768kHz$	-	160	300	μA
S/N Ratio	SNR	94dB SPL @ 1kHz A-Weighting	-	66	-	dB
Distortion	THD	THD < 1% @ 1kHz	-	127	-	dB SPL
Acoustic Overload Point	AOP	10% THD @ 1kHz, S=Typ	-	129	-	dB SPL
Power Supply Rejection	PSR	100mVpp Squarewave @ 217Hz A-weighting	-	-102	-	dBFS

3.3 Frequency Response Curve and Limits

Typical Free Field Response

Normalized to 1kHz

Standard Mode $V_{DD}=1.8V$, $f_{CLK}=3.072MHz$, Decimation Rate=64x

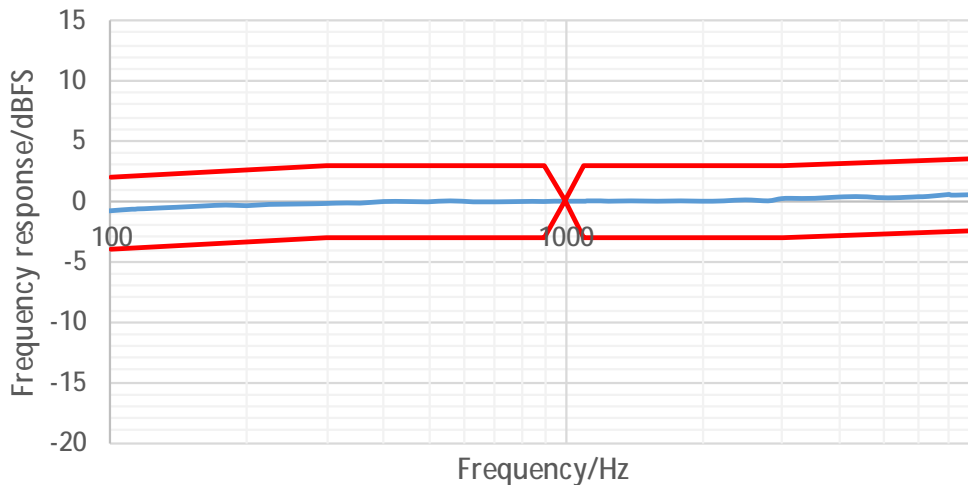

Typical Free Field Response

Normalized to 1kHz

Standard Mode $V_{DD}=1.8V$, $f_{CLK}=2.4MHz$, Decimation Rate=50x

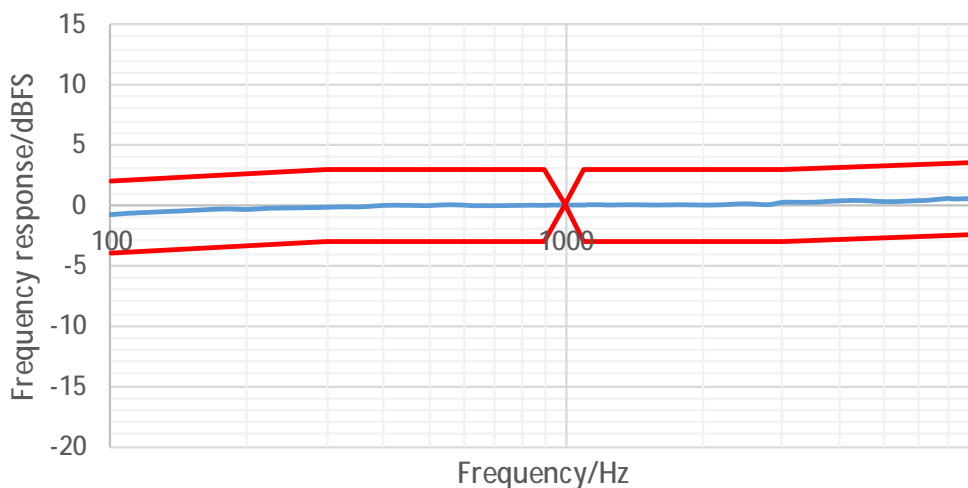

Typical Free Field Response
Normalized to 1kHz
Low Power Mode $V_{DD}=1.8V$, $f_{CLK}=768kHz$, Decimation Rate=48x

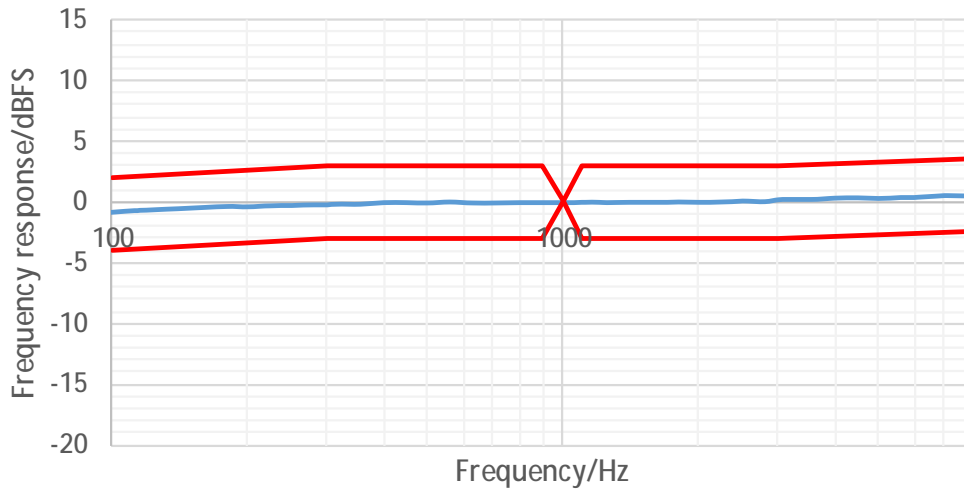

Frequency(Hz)	100	300	500	900	1100	3000	8000
Upper Limit(dBFS)	2	3	3	3	3	3	3.5
Lower Limit(dBFS)	-4	-3	-3	-3	-3	-3	-2.5

3.4 Microphone Interface Specifications

Item	Symbol	Test Conditions	Min	Typ	Max	Unit
Input Logic High Level	V_{IH}		$0.7 \times V_{DD}$	-		V
Input Logic Low Level	V_{IL}			-	$0.3 \times V_{DD}$	V
Clock Duty Cycle			45	-	55	%
Clock Rise/Fall Time	t_{CR}/t_{CF}		-	-	13	nS
Delay Time for Data Driven	t_{DD}	Delay time from CLOCK edge (50% V_{DD}) to DATA driven.	40	-	80	nS
Delay Time for Data High-Z	t_{HZ}	Delay time from CLOCK edge (50% V_{DD}) to DATA high impedance state.	5	-	30	nS
Delay Time for Data Valid	t_{DV}	Delay time from CLOCK edge ($0.50 \times V_{DD}$) to DATA valid ($<0.30 \times V_{DD}$ or $>0.70 \times V_{DD}$)	-	-	120	nS

3.5 General Microphone Specifications

Item	Symbol	Test Conditions	Min	Typ	Max	Unit
Supply Voltage	V _{DD}		1.71	1.8	3.6	V
Clock Frequency Range	Standby Mode	f _{CLK}	-	-	330	kHz
	Low Power Mode	f _{CLK}	730	768	1020	kHz
		f _{CLK}	1.17	1.536	1.70	MHz
	Standard Mode	f _{CLK}	1.9	2.4	2.6	MHz
		f _{CLK}	2.9	3.072	3.4	MHz
Directivity			Omni-directional			
Polarity		Increasing Sound	Increasing density of 1's			
Data Format			½ Cycle PDM 1bit			
Short Circuit Current	I _{sc}	Grounded Data Pin	1	-	20	mA
Output Load Capacitance on DATA	C _{load}		-	-	100	pF
Start-up Time		Time to start up in either modes (Low Power- and Normal Mode) after V _{DD} and CLOCK have been applied.	-	-	50	ms
Mode-Change Time		Time to switch between modes (Clock Off-, Low Power-, and Normal Mode). V _{DD} remains on during the mode switch.	-	-	50	ms

Note 1. dBFS = 20xlog (A/B) where A is the level of the signal, B is the level that corresponds to Full-scale level.

Note 2. The current consumption depends on the applied Clock Frequency and the load on the DATA output.

Note 3. Timing

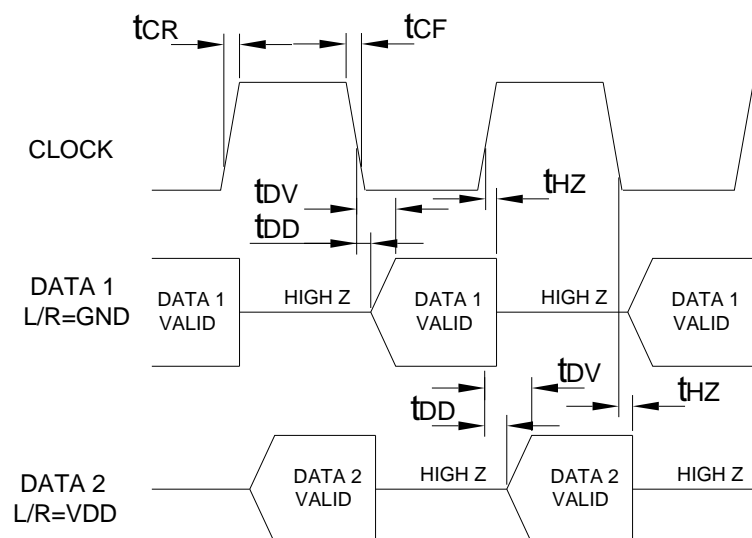

4 Measurement Circuit

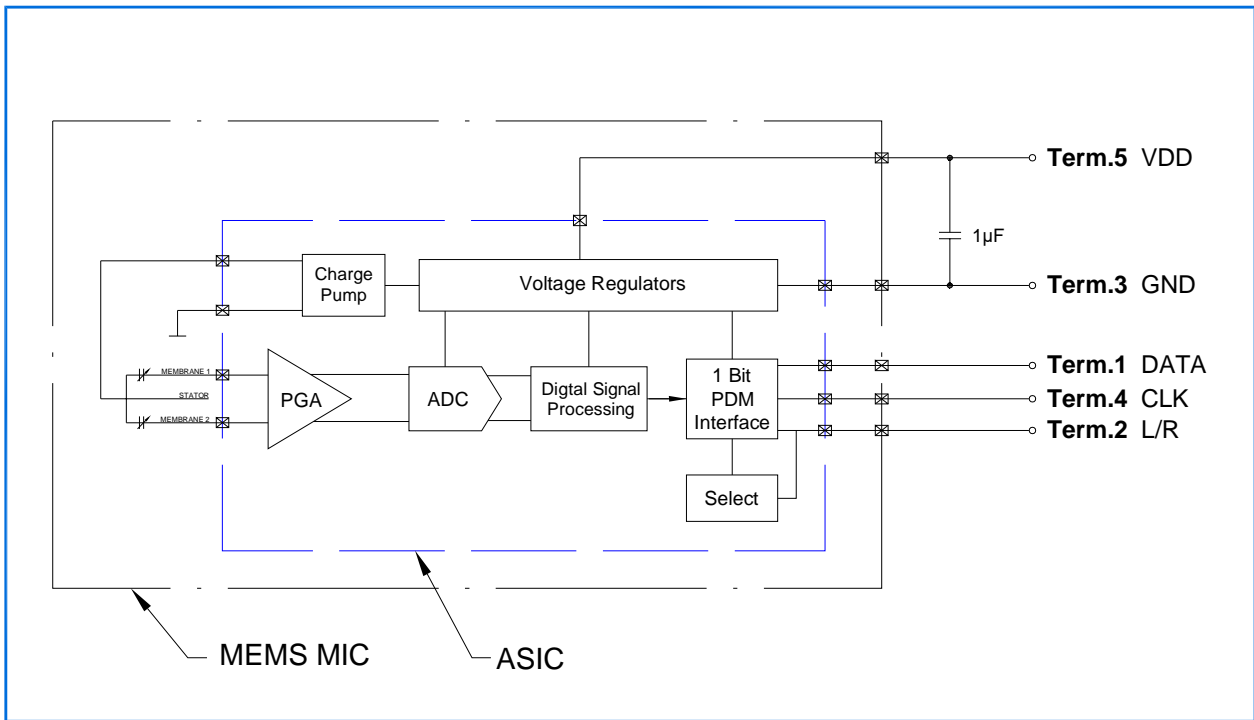

5 Test Setup Drawing

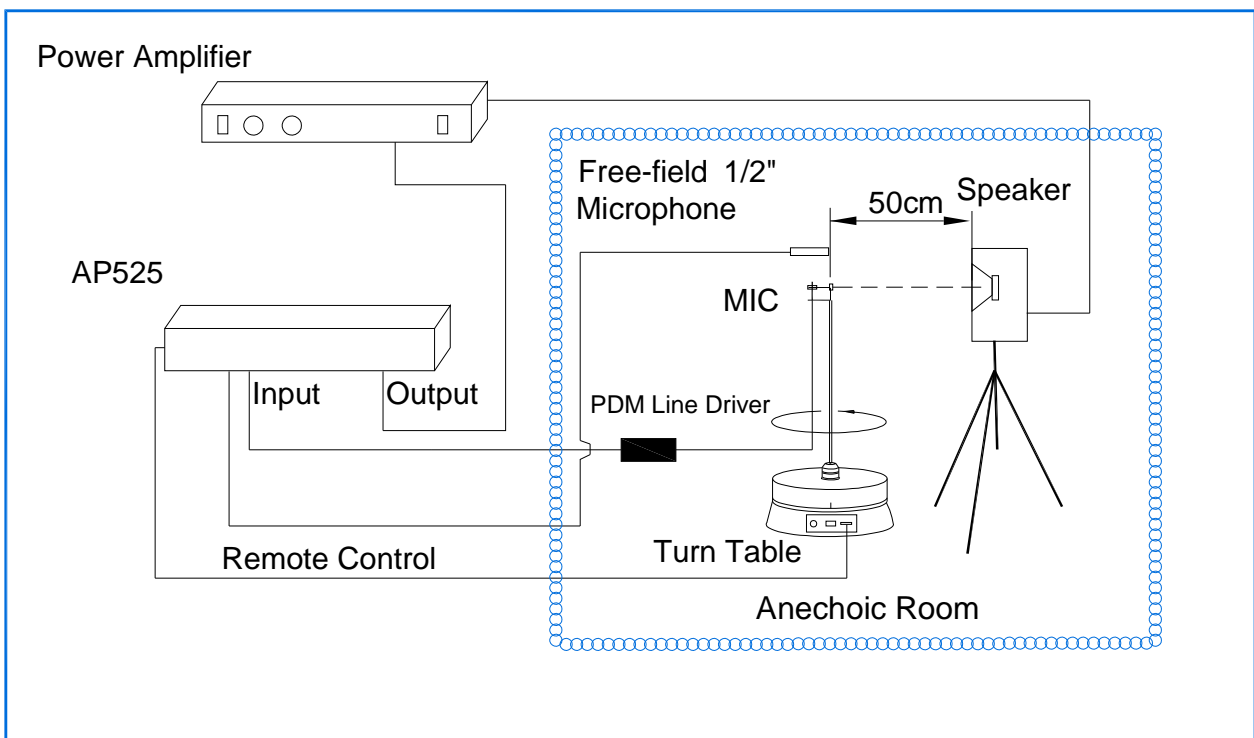

6 Mechanical Characteristics

6.1 Appearance Drawing (Unit: mm)

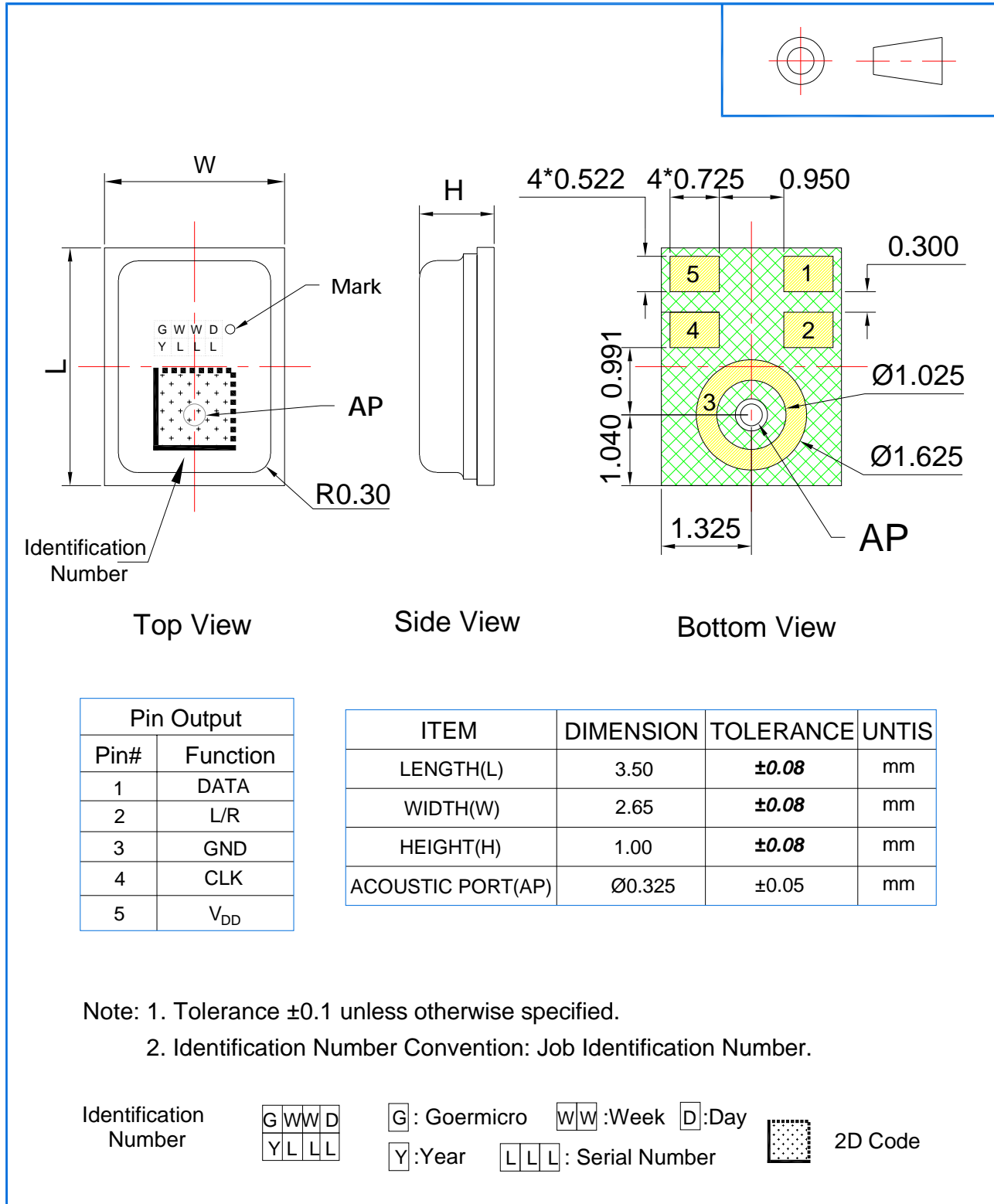

6.2 Weight

The weight of the MIC is Less than 0.05g.

7 Reliability Test

<p>7.1 Vibration Test</p>	<p>To be no interference in operation after vibrations, 4 cycles, from 20 to 2,000Hz in each direction(X,Y,Z), 48 minutes, using peak acceleration of 20g, sensitivity should vary within ± 3dBFS from initial sensitivity. (The measurement to be done after 2 hours of condition at 15°C-35°C, R.H. 25%~75%)</p>
<p>7.2 Drop Test</p>	<p>To be no interference in operation after dropped to 1.0cm steel plate 12 times from 1.5 meter height in state of JIG,JIG weight of 100g, sensitivity should vary within ± 3dBFS from initial sensitivity. (The measurement to be done after 2 hours of condition at 15°C-35°C, R.H. 25%~75%)</p>
<p>7.3 Temperature Test</p>	<p>a) After exposure at +125°C for 200 hours, sensitivity should vary within ± 3dBFS from initial sensitivity. (The measurement to be done after 2 hours of condition at 15°C-35°C, R.H. 25%~75%) b) After exposure at -40°C for 200 hours, sensitivity should vary within ± 3dBFS from initial sensitivity. (The measurement to be done after 2 hours of condition at 15°C-35°C, R.H. 25%~75%)</p>
<p>7.4 Humidity Test</p>	<p>After exposure at +85°C and 85% relative humidity for 200 hours, sensitivity should vary within ± 3dBFS from initial sensitivity. (The measurement to be done after 2 hours of condition at 15°C-35°C, R.H. 25%~75%)</p>
<p>7.5 Mechanical Shock Test</p>	<p>Then subject samples to three one-half sine shock pulses (3000 g for 0.3 milliseconds) in each direction (for six axes in total) along each of the three mutually perpendicular axes for a total of 18 shocks, sensitivity should vary within ± 3dBFS from initial sensitivity. (The measurement to be done after 2 hours of condition at 15°C-35°C, R.H. 25%~75%)</p>
<p>7.6 Thermal Shock Test</p>	<p>After exposure at -40°C for 30 minutes, at +125°C for 30 minutes (change time 20 seconds) 32 cycles, sensitivity should vary within ± 3dBFS from initial sensitivity. (The measurement to be done after 2 hours of condition at 15°C-35°C, R.H. 25%~75%)</p>
<p>7.7 Reflow Test</p>	<p>Adopt the reflow curve of item 12.3, after three reflows, sensitivity should vary within ± 2dBFS from initial sensitivity. (The measurement to be done after 2 hours of condition at 15°C-35°C, R.H. 25%~75%)</p>
<p>7.8 Electrostatic Discharge Test</p>	<p>Under C=150pF, R=330ohm. Air discharge to case with ± 8kV and contact discharge to I/O terminals with ± 2kV, 10 times, Grounding. Sensitivity should vary within ± 3dBFS from initial sensitivity.</p>

8 Package

8.1 Tape Specification

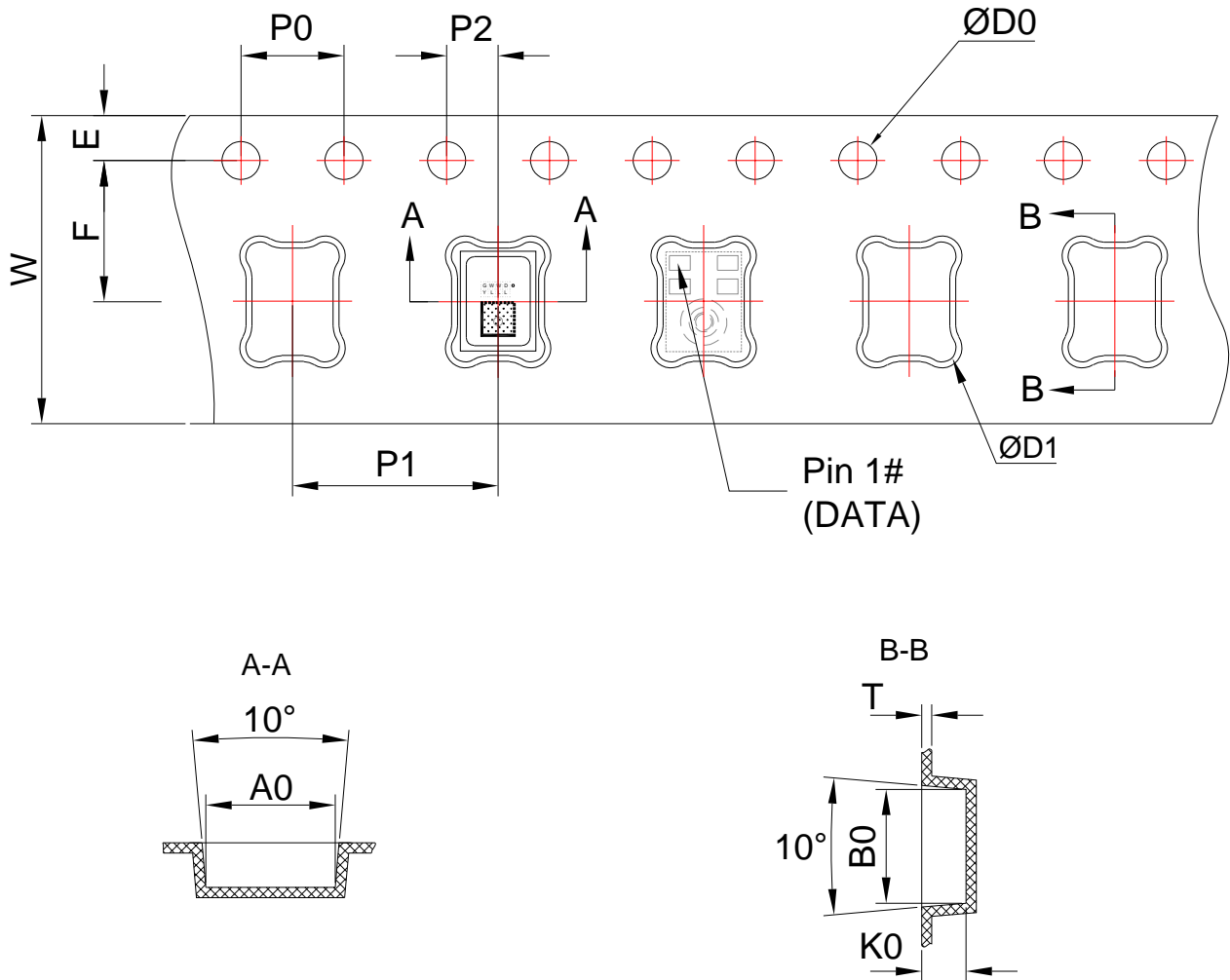

The Dimensions as Follows:

ITEM	W	E	F	ØD0	K0
DIM(mm)	12.0±0.30	1.75±0.10	5.5±0.05	1.50 ^{+0.10} ₀	1.30±0.10
ITEM	P0	10P0	P1	A0	B0
DIM(mm)	4.00±0.10	40.00±0.20	8.00±0.10	2.85±0.05	3.75±0.05
ITEM	P2	T			
DIM(mm)	2.00±0.05	0.30±0.05			

8.2 Reel Dimension

7" reel for sample stage

13" reel will be provided for the mass production stage

The following is 13" reel dimensions (unit:mm)

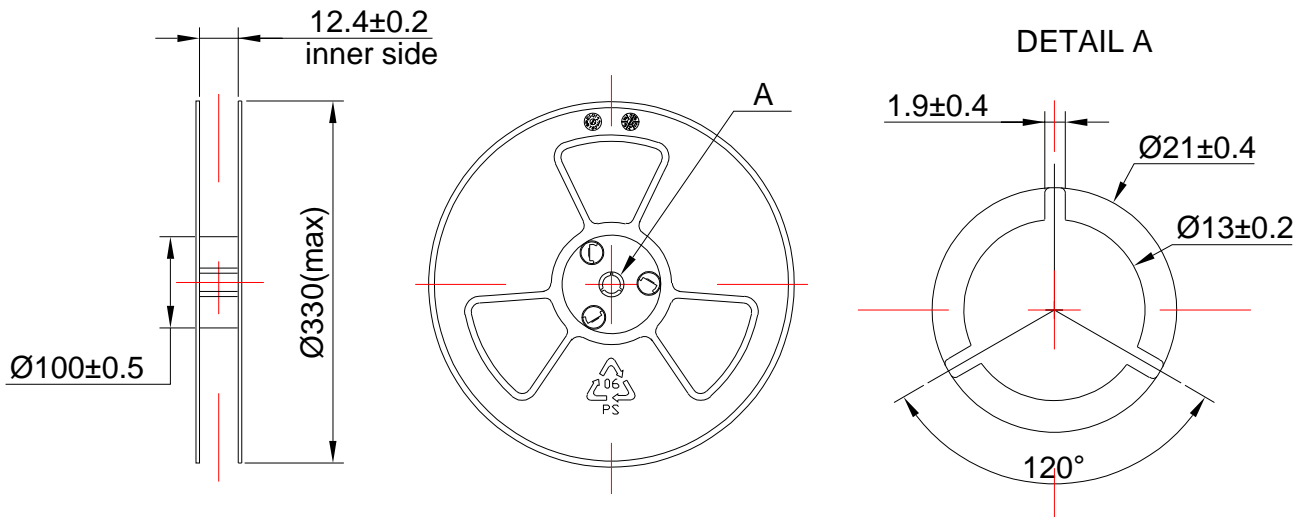

8.3 The Content of Box(13" reel)

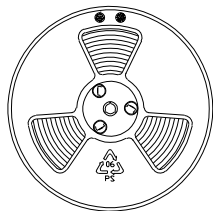

Packing (5,000PCS)



Antistatic bag(5,000PCS)

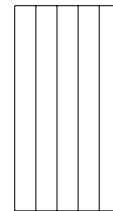

Five Antistatic bag(25,000PCS)

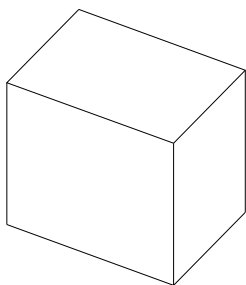

Inner Box(25,000PCS)
(355mm×130mm×345mm)

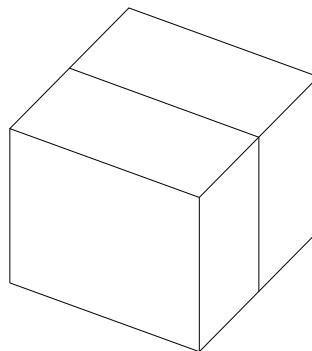

Two Inner Box(50,000PCS)

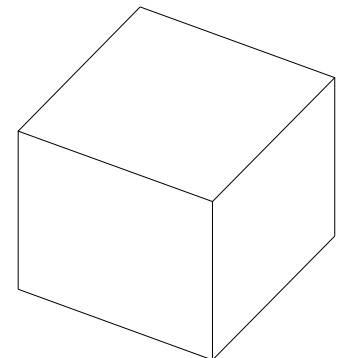

Outer Box(50,000PCS)
(365mm×295mm×380mm)

8.4 Packing Explain

8.4.1 The Label Content of the Reel

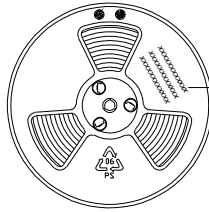

The Content Includes:
Product type, Lot, Customer P/N;
and other essential information such as
Quantity, Date etc.

8.4.2 The RoHS Label

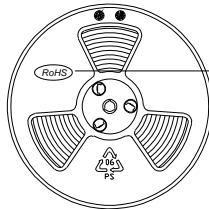

RoHS HF
Compliance Mark

9 Storage and Transportation

- 9.1 Keep MEMS MIC in warehouse with less than 75% humidity and without sudden temperature change, acid air, any other harmful air or strong magnetic field. Recommend storage period no more than 1 year and floor life(out of bag) at factory no more than 4 weeks.
- 9.2 The MEMS MIC with normal pack can be transported by ordinary conveyances. Please protect products against moist, shock, sunburn and pressure during transportation.
- 9.3 Storage Temperature Range: $-40^{\circ}\text{C} \sim +70^{\circ}\text{C}$
- 9.4 Operating Temperature Range: $-40^{\circ}\text{C} \sim +70^{\circ}\text{C}$

10 Land Pattern Recommendation

10.1 The Pattern of MIC Pad(Unit:mm)

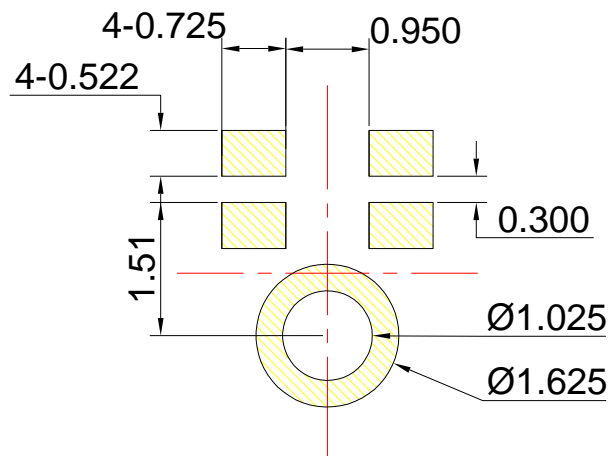

10.2 Recommended Soldering Surface Land Pattern (Unit:mm)

Recommended the size of solder stencil pattern area is >80% of MIC pads, as below, and the stencil thickness suggestion is 0.1mm.

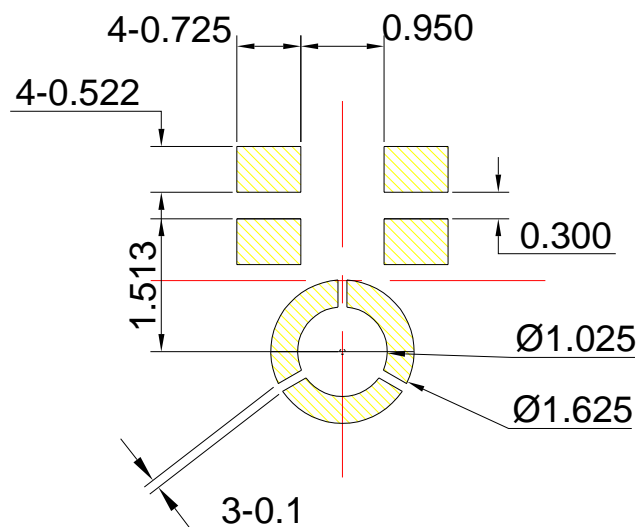

11 Soldering Recommendation

11.1 Soldering Machine Condition

Temperature Control	8 zones
Heater Type	Hot Air
Solder Type	Lead-free

11.2 The Drawing and Dimension of Nozzle

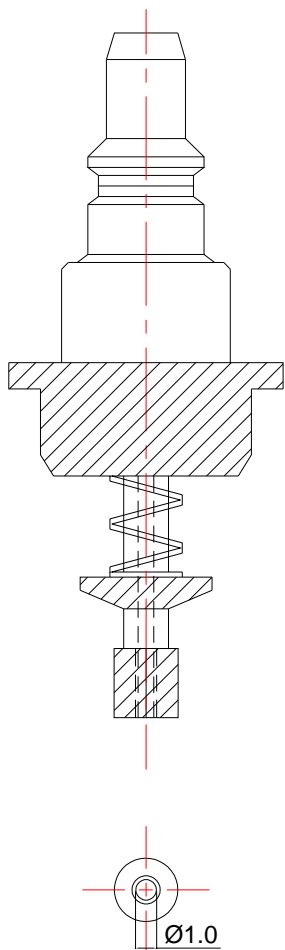

Inside Diameter: $\varnothing 1.0\text{mm}$;
Acoustic Port: $\varnothing 0.6\text{mm}$;

Please don't vacuum over the acoustic port directly.
Please don't blow the acoustic port directly.

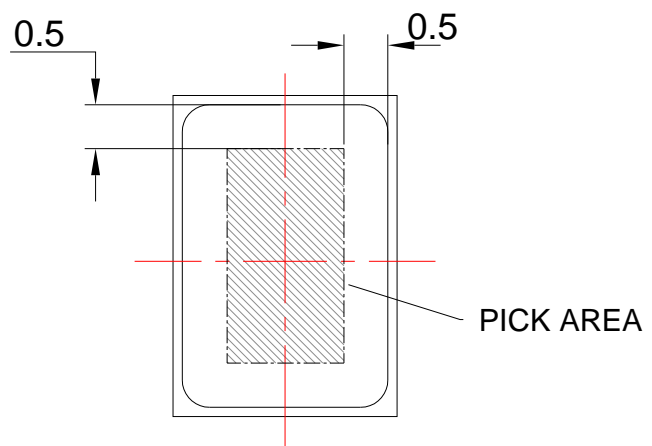

11.3 Reflow Profile

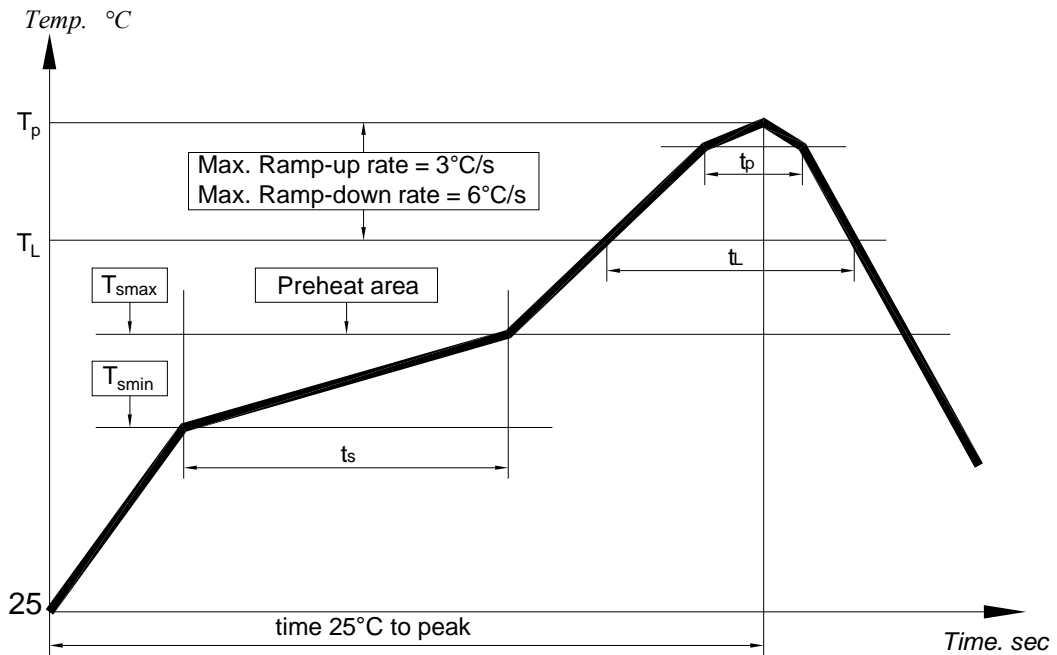

Key Features of The Profile:

Average Ramp-up rate(T_{smax} to T_p)	3°C/s max.
Preheat : Temperature Min(T_{smin}) Temperature Max(T_{smax}) Time(T_{smin} to T_{smax})(t_s)	150°C 200°C 60~180s
Time maintained above : Temperature(T_L) Time(t_L)	217°C 60~150s
Peak Temperature(T_p)	260°C
Time within 5°C of actual Peak Temperature(t_p) :	30~40s
Ramp-down rate(T_p to T_{smax})	6°C/s max
Time 25°C to Peak Temperature	8min max

When MEMS MIC is soldered on PCB, the reflow profile is set according to solder paste and the thickness of PCB etc.

12 Cautions

12.1 Board Wash Restrictions

It is very important not to wash this microphone, otherwise this could damage the microphone.

12.2 Ultrasonic Restrictions

It is very important not to use ultrasonic process. otherwise this could damage the microphone.

12.3 Acoustic Port Protection

It is very important not to operate vacuum and air blow into acoustic port(without any covering over acoustic port), otherwise this could damage the microphone.

And it is necessary to be careful about foreign substances into acoustic port .Please add protection material (e.g. PET) on the acoustic hole to protect it after SMT , refer to below pictures, take it away before test, then attach it again until the end of assembly.

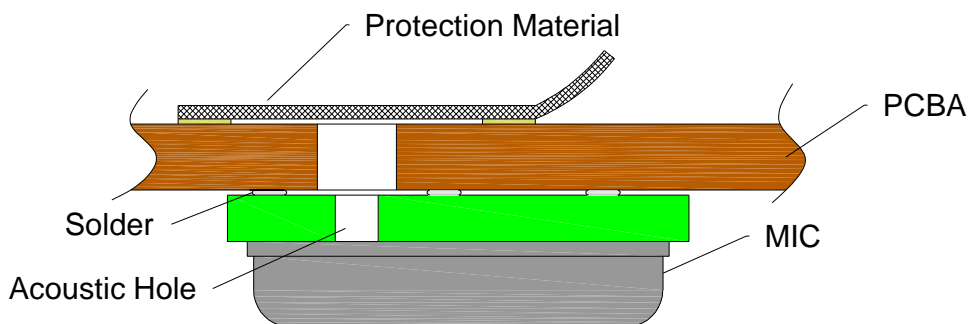

13 Output Inspection Standard

Output inspection standard is executed according to <<ISO2859-1:1999>>.